

Qlamp LED Wall Light 30W

Q-RSD-008



DESCRIPTION:

- This type of fixture is used to illuminate a variety of areas such as: lighting building facades, parking areas, garages, loading areas and any other space requiring reliable safety and security.
- Huge LED retrofit market and new applications are also available in your marketplace.
- For difficult architectural illumination applications consider LED wall pack retrofit kits.
- High lumen output, energy-efficient optical control and easy universal installation features confirm the LED wall pack as the absolute choice for indoor and outdoor illumination.



TECHNICAL SPECIFICATION	
Model No.	Q-RSD-008
Beam Angle	120°
Light Source/Count	110pcs 5630 SMD LED
Lamp Base	2PIN Wires
LED Luminous Efficiency	>100lm/w
Luminous Flux	3000 lm ±10%
Color Temperature Standard	WW (2700~3500K)
	NW (4000~5000K)
	CW (5500~6700K)
Color Rendering Index (CRI)	Ra>70
LED Emitter Life	50,000hours
Replacement	HPS 90W
IP Rating	IP65
Applications	Lighting building facades, loading areas, garages, custom applications, etc...
Driver Model	MEAN WELL: CEN-60-36
Input Voltage	100-240VAC / 50-60Hz
PF	>0.95
Power Efficiency	>87%
Rated Power	32W
Operating Temperature	-40°C~45°C
The Dimensions	363*230*195mm
N.W/ G.W	4.25kg / 5.5kg
Packing	1pc/ Box

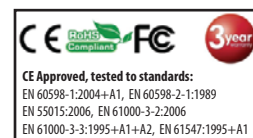
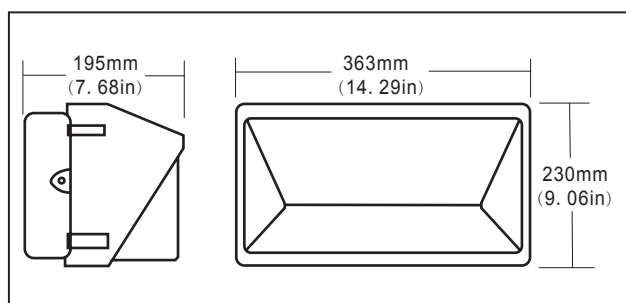

POWERSAVE SOLUTIONS LTD

HEAD OFFICE: Unit 7, The Sandon Estate, Sandon Way, Liverpool L5, 9YN
LONDON OFFICE: 152-154 Coles Green Road, NW2 7HD

e-mail: info@powersavesolutions.co.uk facebook.com/powersavesolutions www.powersavesolutions.co.uk