

Qlamp New High Bay Light 150W

Q-HB70150

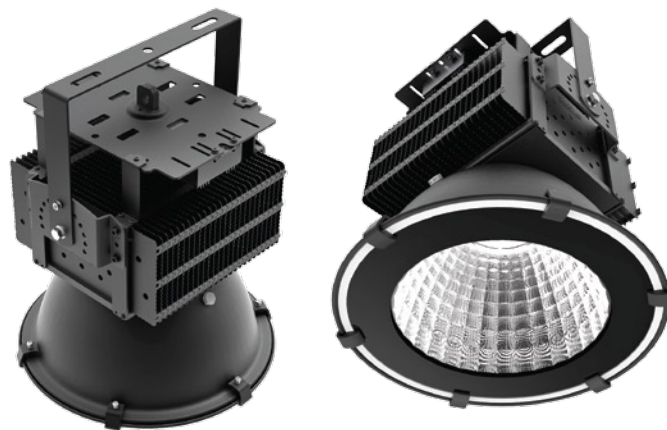

DESCRIPTION:

- **Green Lighting, ECO-friendly:** There is no harmful heavy metals such as mercury, lead and so on, no flicker, start fast, no ultraviolet rays, no attract mosquitoes, no damage because of frequent switch.
- **Safe, efficient:** Adopt internally installed wide voltage and wide frequency constant current topology isolation circuit design for power supply, small size, power conversion efficiency is greater than 88%. There is protection in open circuit, short circuit, overload, lightning surge and other security protection function, with low noise, low temperature, high efficiency, high power factor, energy saving, environmental protection, security, long lifespan.
- **Excellent heat:** Unique thermal body design, perfect combination to electrical box, effectively heat conduction diffusion, so as to reduce the temperature in the body, effectively ensuring the lifespan of the light source and the power supply.
- **Long lifespan:** More than one chip integrated single-mode group of light source, lifespan is above 50,000 hours.

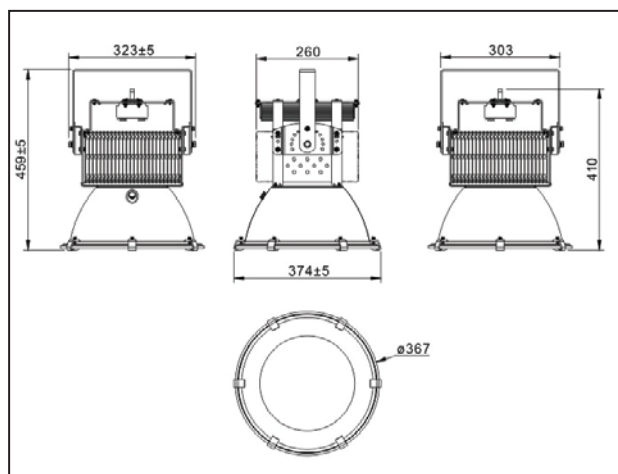

TECHNICAL SPECIFICATION	
Model No.	Q-HB70150
Input Voltage	AC85V-265V
Frequency Range	50-60Hz
Dimension	367*459mm
Total Harmonic Distortion	≤9%
Power Factor	≥0.9
Color Temperature	WW (2700~3200K)
	NW (4000~4500K)
	CW (6000~6500K)
Luminosity	≥10000lm
	≥13000lm
	≥13300lm
CRI (Ra)	>70
LED Quantity	Cree 24*6W XM-L
LED Consumption	144W
System Consumption	150W
Beam Angle	120°
Lamp's Efficiency	>85%
Junction Temperature	≤80°C
Working Temperature	-25°C~+45°C
Material	Alu+PC
IP Grade	IP50
Lumen Attenuation	<5% @ 5,000hrs
Weight: G.W	6.3kg
N.W	5.7kg
Packing Dimension	L47.5*W47.5*H51CM

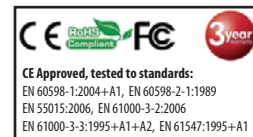

POWERSAVE SOLUTIONS LTD

HEAD OFFICE: Unit 7, The Sandon Estate, Sandon Way, Liverpool L5, 9YN
LONDON OFFICE: 152-154 Coles Green Road, NW2 7HD

e-mail: info@powersavesolutions.co.uk facebook.com/powersavesolutions www.powersavesolutions.co.uk